

Warmup®

The **world's best-selling** electric floor heating brand™

Installation Manual: Underlamine Foil Heater



Complete and submit the warranty form online at www.warmup.co.uk

SAFETY Net™
INSTALLATION
GUARANTEE



IMPORTANT
Read this manual before attempting to install your underfloor heater. Incorrect installation could damage the heater and will invalidate your warranty.

TECHNICAL HELPLINE

0845 345 2288

IMPORTANT!

Do not place items such as bean bag furniture, thick rugs or floor-flush furniture on your heated floor covering.

Use of such items while the heater is operating may result in a build-up of heat which could damage your floor covering.

Getting Started

Before installing your new Warmup® underlamine foil heating mats, be sure you have the following additional parts:

Electrical junction box – used as the connecting junction for the electrical supply cables of the heating mats.

Control thermostat – allows you to control the temperature of the room.

Residual Current Device - Consult your electrician regarding the applicable RCD.

Hard insulation materials – used as heat insulator under the foil heating mats in installations with concrete subfloors to provide more efficient heating. The material comes in plates, usually made from foamed Polyurethane or Polystyrene and should have Compressive strength of more than 28PSI (2Kg/cm²). An example of this is the Warmup® Insulation Board.

Soft insulation material – any soft insulation suitable for wood or laminate. which has a fire rating of B2 or greater.

Your Warmup® Underlamine Foil Heater has been designed so that installation is quick and straight forward, but with all electrical systems, certain procedures must be strictly followed.

Please check the sizing guide at the back of this manual to ensure that you have the correct heater(s) for the area you wish to heat.

Contents

- ② Getting Started
- ④ Important!
- ⑥ About the Product/
Modifying Your Heating Mats
- ⑦ **Step 1:**
Planning Your Installation
- Step 2:**
Laying Out Your Foil Heating Mats
- ⑨ **Step 3:**
Making the Electrical Connections
- ⑬ Installation Examples
- ⑯ Standard sizes of foil heating
mats and their values

NOTICE:

**This product MUST be used
with a dedicated 30 mA RCD
(residual current device)**

If these instructions are followed you should have no problems.
However, if you do require help at any stage, please call our 24hr helpline:

Warmup Technical Helpline 0845 345 2288

You can also find a copy of this manual, wiring instructions, a list of frequently asked questions and more helpful information on our website: www.warmup.co.uk

Important!

Please read carefully before installing your Warmup® underlamine foil heating mats.

DON'T:

- DON'T** leave insulating materials such as bean bags; linen or towels on the floor surface. The maximum thermal resistance recommended between the heater and the room is 0.15 m²K/W (1.5 TOG).
- DON'T** overlap heating mats.
- DON'T** fold or wrinkle Warmup® Underlamine foil heating mats.
- DON'T** place heavy/sharp tools (or any other potentially damaging object) on top of the heating mats.
- DON'T** walk unnecessarily on the foil heating mats.
- DON'T** install electrical cables or pipes under the floor with the foil heating mats.
- DON'T** use cellulose insulation.
- DON'T** install mats when the room temperature is below -5°C.
- DON'T** install foil heating mats anywhere except inside buildings.
- DON'T** install foil mats under walls or partitions, or in areas under heavy cabinets, closets, or fixtures (toilets, sinks, tubs, etc.).
- DON'T** install foil mats within 30mm of any heat conductive building part, such as cold water pipes.
- DON'T** install foil mats within 10mm of one another, 50mm of any wall, or 150mm of a fireplace or hot water pipe.
- DON'T** connect any other electrical appliance on the same electric fused spur or RCD/SPUR unit of the heating system
- DON'T** install foil heating mats under wooden floor, if the wooden floor is thicker than 18 mm.
- DON'T** put acoustic material between the foil heating mats and the wooden floor, installing wooden type floor.
- DON'T** use this heater under any floor covering other than wood or laminate flooring.
- DON'T** place items on the floor surface which will stop the air flow or not allow heat to rise into the room.

WARNING

Once the foil heating mat has been installed avoid all traffic over the mat until the floor has been laid.

Do not install the foil heating mat until the floor is ready to be laid. If the floor is not being laid immediately, all heating mats must be protected with two layers of cardboard or hardboard to prevent damage.

Immediately prior to the floor being laid, check it has not been damaged in transit.

If you are in any doubt call the Warmup helpline on **0845 345 2288**

Important!

ALWAYS:

- ALWAYS** ensure all earth leads are connected to the earth ring.
- ALWAYS** ensure that the electric circuit that supplies electricity to the Warmup® Underlamine heating system is equipped with a 30mA residual current device (RCD).
- ALWAYS** connect all cold wire leads from the Warmup® Underlamine foil heating mats in parallel inside an electrical junction box or boxes.
- ALWAYS** ensure that the total current needed for all mats connected in parallel is not more than 80% of the listed amperage capacity of the electrical junction box and its power supply line and breaker (For advice consult your recommended Part P qualified electrician).
- ALWAYS** provide each room with an Warmup® Underlamine foil heating system with its own electrical junction box and control thermostat. Each Warmup® thermostat has a maximum capacity of 16 Amps. If the amount of Amps in the room is greater than 16 Amps, divide the amperage over several thermostats. (To calculate the amount of Amps in the room see tables in page 16).
- ALWAYS** use insulation under the mats to reduce running costs and warm-up time. Check with your installer to determine the R value of the sub floor insulation layer. If there is no insulation, or if the R value of the insulation layer is lower than $0.57\text{ft}^2\text{h}^{\circ}\text{F}/\text{Btu}$ ($0.1\text{m}^2\text{C}/\text{W}$ or 1 Tog), please read the insulation instructions on page 6 and act accordingly.
- ALWAYS** ensure that no sharp edges (e.g. metal-edged laminate locking systems) come in contact with the foil heating.
- ALWAYS** fit the floor sensor and ensure that the thermostat is set for the correct heater type and floor finish.

Note: Timber products often have a limitation on the maximum temperature allowed for floor heating- This is usually around 27°C. Check with your flooring supplier what the limitations are for your preferred floor finish.

As with all electrical projects which are subject to Part P Building Regulations, all electrical work should be carried out by a certified/qualified electrician.

All work must conform to BS 7671:2008 and the current IEE Wiring Regulations.

About the Product

Specifications:

Construction:	Aluminium foil heater with fluoropolymer insulated twin-conductor, sandwiched between 2 layers of specially reinforced aluminium foil.
Standard Wattage:	80 W/SqM and 140 W/SqM (see page 16 for individual mat specifications)
Mat Width:	500mm
Heating cable spacing:	50mm
Cold lead length:	3m

Modifying Your Heating Mats

Cutting and turning the mat:

In some instances, you may need to cut and turn the mat to suit the room.

It is essential that you do not cut, twist or kink the heating wire.

To make a cut, turn the mat over so that the loops are exposed. Lift the wire out of the way when cutting. Once the aluminium foil has been cut and the mat has been repositioned, use the aluminium tape provided to cover the exposed wire and link the two pieces of the mat.

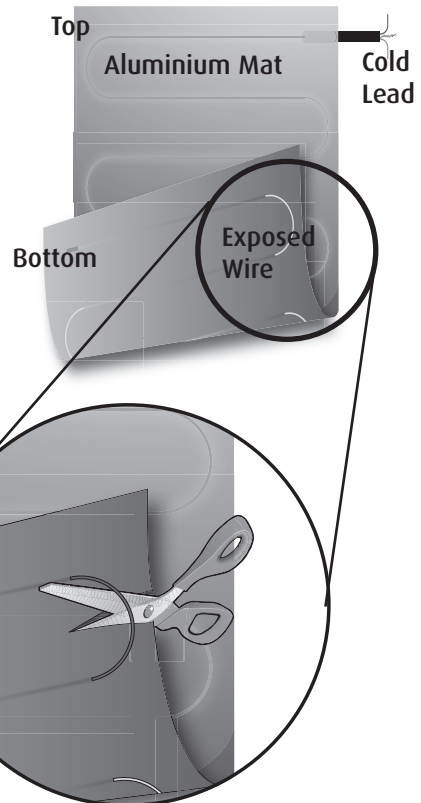
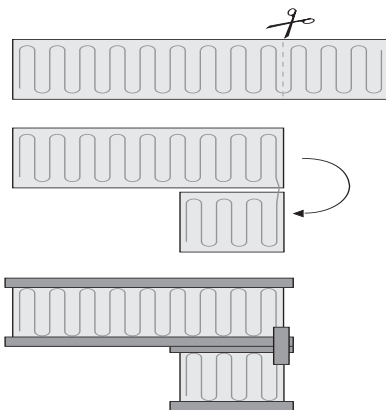

Step 1: Planning Your Installation

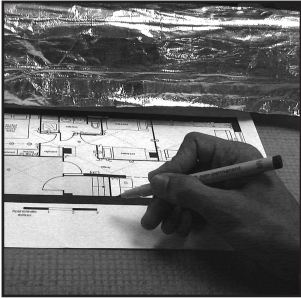

Before installing, draw an installation plan showing the placement of the mats, floor sensor, and junction box or boxes.

The Warmup® underlamine foil heating mats should cover at least 80% of the floor area of your room to be used as a primary heat source*. Warmup's foil heating mats are available in several convenient sizes. Choose the combination of heating mats that best enables you to cover the recommended 80% of your room. Plan to use the larger foil heating mats as much as possible and to use smaller mats only as gap fillers.

Note: The mats are supplied with 3 metres of electrical cold leads. If this is not enough, ask your electrician to extend the electrical supply cables.

*Depending on insulation, air-flow & overall heat-loss within the room, additional heating may be required.

Step 2: Laying Out Your Heating Mats

- 1 Clean all debris from the floor base.
- 2 Insert Insulation as per the manufacturer's instructions
- 3 Clean all debris from the surface of the insulating material.
- 4 Roll out heating mats on top of the insulating material. It is recommended to leave a gap of about 50mm from the wall to the heating mats, and a gap of about 10mm between each mat. Ensure that each heating mat is completely flat. Make sure that the cold leads of the mats are on the side of the mat that is closest to the location of the electrical junction box (See step 3 – Making the Electrical Connection).

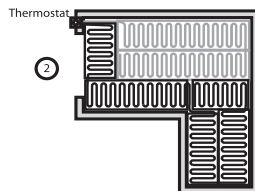
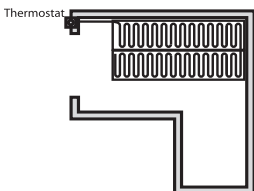

NOTE:
When laying two or more heaters, ensure the cold tails reach the thermostat.

Step 2: Laying Out Your Heating Mats

- ① Power Supply
- ② Electrical wire installed in an electric conduit
- ③ Junction box
- ④ Electrical supply cables
- ⑤ Foil heating mat
- ⑥ Thermostat
- ⑦ Floor sensor installed in an electric conduit
- ⑧ Floor sensor installed in floor (equal distance between heating foils)

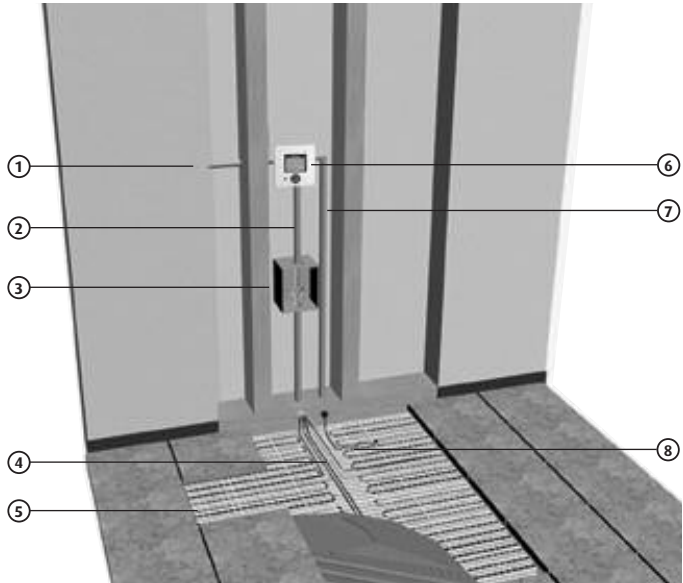

- 5 Your mats come with aluminium tape. Stretch the mats and secure the mats to the floor with the tape. Where required, additional duct tape can be used.

If any wire has been detached from the foil mat (when mat is cut and turned), that wire **MUST** be covered by aluminium tape, and bridge the gap between the sections of mat.

This is necessary in order to keep the earth circuit intact.

- 6 Place the electrical supply cables of the mats between the mats toward the junction box. Place the electrical supply cables so that they do not cross each other.

Important!

Ensure that the electrical supply cables of the mats do not cross over the mats.

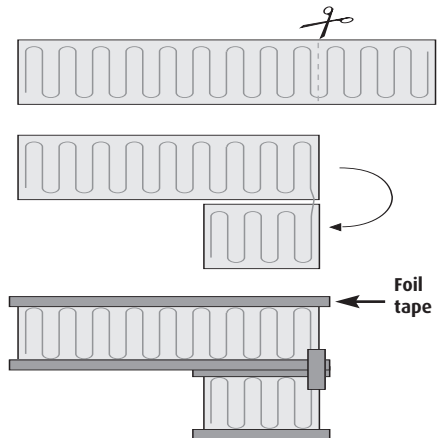

Step 2: Laying Out Your Heating Mats

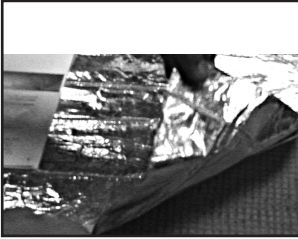

7 Since the joint is slightly thicker than the rest of the mat, create a slight groove in the insulation board under the joint to ensure that the heating mat lays flat.

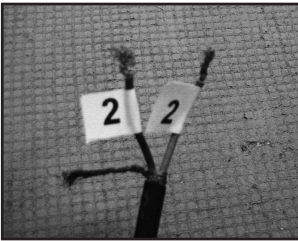

8 Mark each pair of cold leads coming from the same mat with a number. Place a small sticker with the number of each pair of leads close to the end of the lead.

Step 3: Making the Electrical Connections



Note: All electrical connections must be performed by a fully qualified and Part P certified electrician.

Important! Tightly screw all connections to ensure good electrical contacts.

- 1** Install the electrical junction box or boxes above floor level according to local safety and building regulations and codes. Place the following label (attached to back cover) on the electrical junction box or boxes indicating that an underfloor heating system is installed in the room.
- 2** Install the control thermostat as far as possible from any heat sources or heat sinks such as fireplaces, direct sunlight, windows, doors, or anything that could possibly affect proper temperature readings. The suggested placement is 1.6m above floor level.
- 3** The thermostat should be connected to the main electrical supply via a suitable double pole isolator fuse or circuit breaker, in accordance with current wiring regulations. The thermostat must be installed in the room or area to be heated, except in bathrooms/wet rooms where the thermostat **MUST** be sited outside of the room.

Step 3: Making the Electrical Connections

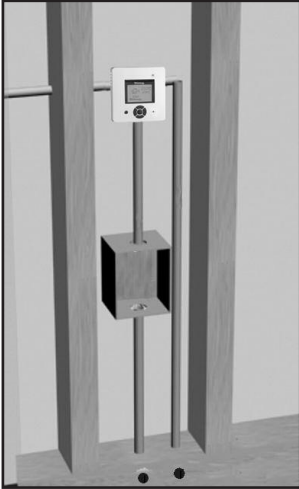

- 4 Install an electric conduit to the junction box and thermostat as in the following diagram.



- 5 Connect the floor temperature safety sensor to the thermostat through a conduit, and install between two heating wire runs on the mat, at least 500mm from the wall.



- 6 Create a groove in the subfloor to accommodate the floor sensor conduit.

Note: Make sure that the sensor is placed between two runs of wire, at the opposite end from the heating wire loop.

The probe wire must not touch or be crossed by the heating element.

The end of the conduit must always remain accessible if removal/insertion of the sensor is required in the future

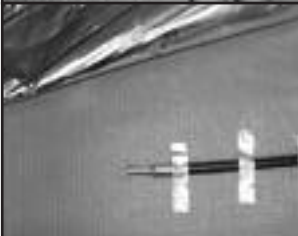

Step 3: Making the Electrical Connections



- 7** Measure the resistance of the heating system and record the value. Verify that the values you measure are in line with the resistance value that is printed on the specific mat nameplate.

NOTE: the floor sensor values can be found with the thermostat instructions

- 8** All earth connections from the heaters must be connected to the earth from the power supply of the house.
- 9** In parallel, feed each mat to the electrical junction box. Make sure that you can see the sticker with the numbers of the leads. If necessary, shorten the leads, but make sure the sticker with the leads' numbers are affixed to the shortened lead.
- 10** Expose the conductor in each lead.
- 11** Connect all leads of the same colour.
- 12** Insert each coloured lead to one connector in the junction box.
- 13** Connect the same colour cold lead between the thermostat and the connector in the junction box.

WARNING:

This product MUST be used with a dedicated 30MA RCD (residual current device).

The RCD should be tested regularly in accordance with the manufacturer's guidelines.

Step 3: Making the Electrical Connections

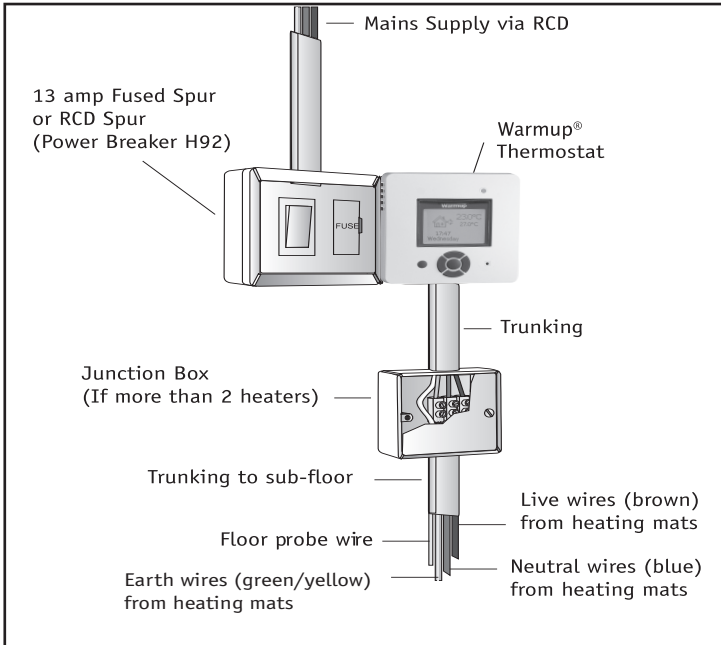

- 14** Connect the wires to the control thermostat according to the wiring instructions found in the thermostat box.
- 15** Switch on the foil heating system (see the directions in your thermostat manual) for half an hour to ensure that the system is working properly. It is important to check each entire system to ensure each foil mat is heating.
- 16** Switch off the heating system (see the directions in your thermostat manual).
- 17** When the mats are cool, lay down your floor covering.

Under wood or laminate flooring

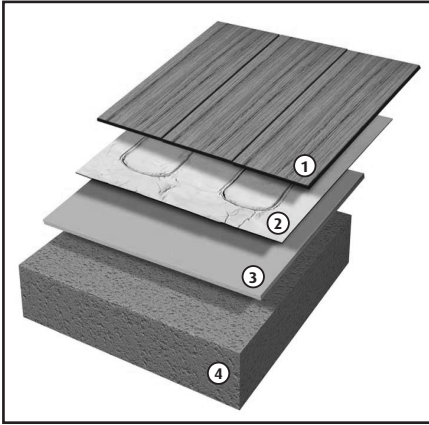

- ① Wood flooring material
- ② Heating mat
- ③ Insulation material
- ④ Floor slab (wood or concrete)

Hard insulation materials – used as heat insulator under the foil heating mats in installations with concrete subfloors to provide more efficient heating. The material comes in plates, usually made from foamed Polyurethane or Polystyrene and should have Compressive strength of more than 28PSI (2Kg/cm²). An example of this is the Warmup[®] Insulation Board.

Soft insulation material – any soft insulation suitable for wood or laminate, which has a fire rating of B2 or greater.

NOTES:

Note: Draw a plan showing the layout and location of the heating mat(s).

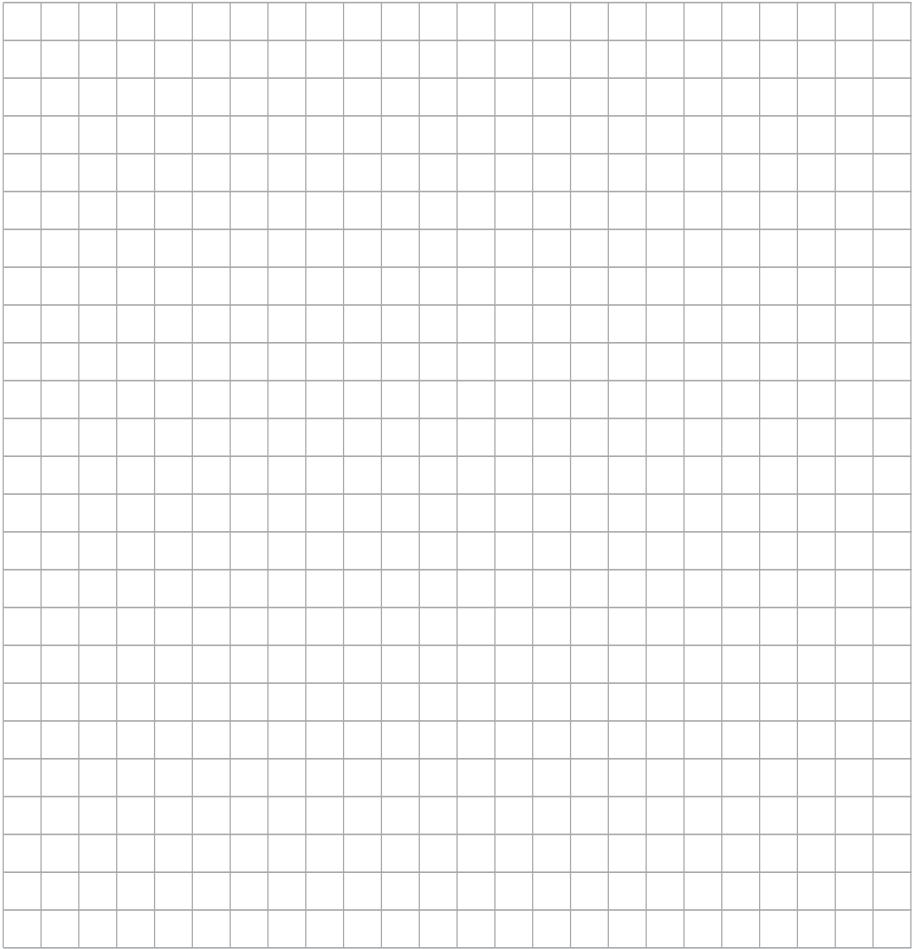



Terms and conditions apply
Models: WLFH heaters manufactured by Warmup PLC –

THE 15-YEAR ELEMENT OF THIS GUARANTEE DOES NOT EXTEND TO THERMOSTATS WHICH ARE COVERED BY SEPARATE GUARANTEES. THIS GUARANTEE DOES NOT AFFECT YOUR STATUTORY RIGHTS.

Warmup® Underfloor Heater is guaranteed by WARMUP PLC ("Warmup") to be free from defects in materials and workmanship under normal use and maintenance, and is guaranteed to remain so subject to the limitations and conditions described below:

The UNDERFLOOR HEATER is guaranteed for 15 Years the lifetime of the floor covering under which it is fitted, except as provided below (and your attention is drawn to the exclusions listed at the end of this guarantee).

This lifetime guarantee applies:

1. only if the unit is registered with Warmup within 30 days after purchase. Registration can be completed by filling out the card accompanying this guarantee or online at www.warmup.co.uk. In the event of a claim, proof of purchase is required, so keep your invoice and receipt – such invoice and receipt should state the exact model that has been purchased; and

2. only if the heater has been earthed and protected by a Residual Current Device (RCD) at all times.

Thermostats are guaranteed for a period of 3 YEAR from the date of purchase, except as provided below.

Neither guarantee continues if the floor covering over the heater(s) is damaged, lifted, replaced, repaired or covered with subsequent layers of flooring.

The guarantee period begins on the date of purchase. Registration is confirmed only when a letter of confirmation is sent by Warmup PLC.

During the period of the guarantee Warmup will arrange for the heater to be repaired or (at its discretion) have parts replaced free of charge. The cost of repair or replacement is your only remedy under this guarantee which does not affect your statutory rights. Such cost does not extend to any cost other than direct cost of repair or replacement by Warmup and does not extend to costs of relaying replacing or repairing any floor covering or floor.

If the heater fails due to damage caused during installation, this guarantee does not apply. It is therefore important to check that the heater is working (as specified in the installation manual) prior to laying the floor covering.

WARMUP PLC SHALL IN NO EVENT BE LIABLE FOR INCIDENTAL OR CONSEQUENTIAL DAMAGES, INCLUDING BUT NOT LIMITED TO EXTRA UTILITY EXPENSES OR DAMAGES TO PROPERTY.

WARMUP PLC is not responsible for:

1. Damage or repairs required as a consequence of faulty installation or application.
2. Damage as a result of floods, fires, winds, lightning, accidents, corrosive atmosphere or other conditions beyond the control of Warmup PLC.
3. Use of components or accessories not compatible with this unit.
4. Products installed outside the United Kingdom.
5. Normal maintenance as described in the installation and operating manual, such as cleaning thermostat.
6. Parts not supplied or designated by Warmup.
7. Damage or repairs required as a result of any improper use, maintenance, operation or servicing.
8. Failure to start due to interruption and/or inadequate electrical service.
9. Any damage caused by frozen or broken water pipes in the event of equipment failure.
10. Changes in the appearance of the product that does not affect its performance.



SafetyNet™ Installation Guidelines:

1. Purchase a Warmup® Underlamine Heater, and follow all recommended installation procedures in the Installation Manual. Failure to follow the instructions will invalidate the guarantee.

2. If you make a mistake and damage the new heater before laying the floor covering, return the damaged heater, to Warmup within 30 DAYS along with your original dated sales receipt. WARMUP WILL REPLACE ANY HEATER (MAXIMUM 1 HEATER) WITH ANOTHER HEATER OF THE SAME MAKE AND MODEL-FREE.

3. If you damage the new heater during installation of the floor covering, contact Warmup immediately to arrange for a site visit. You will need to show our engineer your original dated sales receipt. WARMUP WILL NOT CHARGE YOU FOR THE FIRST SITE VISIT- ON THIS FIRST VISIT THE ENGINEER WILL ATTEMPT TO REPAIR THE DAMAGED HEATER (MAXIMUM 1 VISIT AND 1 HEATER PER RESIDENCE) FOR FREE.

Please note:

(i) Repaired heaters carry a 5 year warranty only. Under no circumstances is Warmup responsible for the repair or replacement of any flooring which may be removed or damaged in order to affect the repair.

(ii) The SafetyNet™ Installation Guarantee does not cover any other type of damage, misuse, or improper installation due to improper adhesive or subfloor conditions. Limit of one free replacement heater per customer or installer.

(iii) Damage to the heater that occurs after laying the floor covering is not covered by the SafetyNet™ Installation Guarantee.

Standard sizes of foil heating mats and their values

140W

Model	Area SQM	Length (m)	Width (m)	Total Watts	Watts / SQM	Amps	Total Resistance
WLFH-140W/140	1	2	0.5	140	140	0.61	377.86
WLFH-140W/210	1.5	3	0.5	210	140	0.91	251.90
WLFH-140W/28	2	4	0.5	280	140	1.22	188.93
WLFH-140W/420	3	6	0.5	420	140	1.83	125.95
WLFH-140W/560	4	8	0.5	560	140	2.43	94.46
WLFH-140W/700	5	10	0.5	700	140	3.04	75.57
WLFH-140W/840	6	12	0.5	840	140	3.65	62.98
WLFH-140W/980	7	14	0.5	980	140	4.26	53.98
WLFH-140W/1120	8	16	0.5	1120	140	4.87	47.23
WLFH-140W/1260	9	18	0.5	1260	140	5.48	41.98
WLFH-140W/1400	10	20	0.5	1400	140	6.09	37.79
WLFH-140W/1680	12	24	0.5	1680	140	7.30	31.49

80W

Model	Area SQM	Length (m)	Width (m)	Total Watts	Watts / SQM	Amps	Total Resistance
WLFH-80W/80	1	2	0.5	80	80	0.35	661.25
WLFH-80W/120	1.5	3	0.5	120	80	0.52	440.83
WLFH-80W/160	2	4	0.5	160	80	0.70	330.63
WLFH-80W/240	3	6	0.5	240	80	1.04	220.42
WLFH-80W/320	4	8	0.5	320	80	1.39	165.31
WLFH-80W/400	5	10	0.5	400	80	1.74	132.25
WLFH-80W/480	6	12	0.5	480	80	2.09	110.10
WLFH-80W/560	7	14	0.5	560	80	2.43	94.46
WLFH-80W/640	8	16	0.5	640	80	2.78	82.66
WLFH-80W/720	9	18	0.5	720	80	3.13	73.47
WLFH-80W/800	10	20	0.5	800	80	3.48	66.13

Business Reply
Licence Number
RLSL-HCUB-JXKB



Warmup PLC
702 Tudor Estate
Abbey Road
LONDON
NW10 7UW



Name _____

Address _____

Post code _____

Telephone number _____

E-mail _____

Installer name _____

Date of purchase _____

Please state which room the heater(s) is installed:

Kitchen

Bathroom

Conservatory

Hall

other _____

I hereby confirm that I have read and understand the contents of the Installation Manual, and that the heater has been installed as specified therein.
I acknowledge that no claim can be brought against the manufacturer or its agents for any consequential loss or damage whatsoever.
I confirm that the heater was working prior to the commencement of tiling.

Signed _____

Date _____

Documentation of Ownership, Installation & Part P Electrical Connection

This form must be filled out **completely**, otherwise you may invalidate your warranty.

Owner's Name _____

Owner's Address _____

Post Code _____ Telephone Number _____

Email _____

Installer's Name _____

Installer's Telephone Number _____

I hereby confirm that I have read & understood the contents of the installation manual & that the heater(s) has been installed as specified therein. I acknowledge that no claim can be brought against the manufacturer or its agents for any consequential loss or damage whatsoever. I confirm that the heater(s) was working prior to tiling.

Installer's Signature _____ Date _____

Electrician's Name _____

Electrician's Address _____

Electrician's Telephone Number _____

Electrician's Part P Certificate Number _____

Table of heaters installed:

Heater/Room	Model No	Serial No.	Batch No.	RCD Rating	Resistance Reading
1 - bathroom	DWS800	225543	0126855	30 Ma	63.9 ohms
2					
3					
4					
5					

Place this card in a visible spot close to the consumer unit.

Warmup

Heater Location _____

Total Wattage _____

CAUTION
 Radiant Floor Heating Systems
 Warming-Risk of electric shock
 Electric-wiring and heating panels
 contained below the floor. Do not
 penetrate with nails, screws, or similar
 devices. Do not restrict the thermal
 emission of the heated floor.



Attention:

Do **not** cut or shorten the heating element wire.

Ensure that the entire heating elements including the joints are installed under the finished floor.

The Heating element must be used in conjunction with a 30mA RCD.

Heater Model	Resistance Before	Resistance After	Insulation Resistance

_____ Date _____ Signed _____ Company stamp/name

This form must be completed as part of the Warmup Guarantee. Ensure that the values are as per the instruction manual.

This card must be situated close to the consumer unit in a visible place.

Note: Draw a Plan showing the layout of the heater.

**702 Tudor Estate
Abbey Road
London
NW10 7UW**

Web: www.warmup.co.uk

Email: uk@warmup.com

Tel: 0845 345 2288

Fax: 0845 345 2299